

## ■ APPS-12-LED

## ■ LED Inpavement Approach Centerline Light (12" 6mm)



### Compliance with Standards

CAAC: AC-137-CA-2015-01  
 CAAC: AC-137-CA-2015-03  
 SAC: GB/T 7256  
 ICAO: Annex 14, Volume I  
 IEC: TS 61827  
 FAA: AC 150/5345-46  
 FAA: EB NO.67  
 NATO: STANAG 3316

### Application/Use

Approach centerline light

### Features

- LED is featured by long life, effective energy saving, maintenance-free, which brings enormous economic benefits
- Proprietary prism structural design and manufacturing process to ensure excellent optical performance
- Strict LED color management to ensure premium color consistency
- Consistent dimming curve with halogen lamp fixture, complying with FAA standards
- Proprietary driving circuit and thermal management solution, which greatly improves the reliability and service life of light fixture
- Power factor above 0.9, minimizing the power network interference
- Optional function of single lamp failure detection, which enables the light to be open as halogen lamp once LED fails
- Specially-designed structure, protruding only 6.35mm above finish grade
- Upper cover with flat out-light surface to prevent from water buildup and ensure high luminous efficiency
- Upper cover with equal-strength design and forging craft, which has premium mechanical, barrier capacity, and shock resistance ability
- Smooth upper cover without sharp edge to prevent aircraft tires from damaging
- Main body of lighting fixture is made of high thermal conductive aluminum alloy, which ensures good heat dissipation performance
- Main structure made of corrosion-resistant aluminum alloy with special anodizing treatment, all fasteners are made of stainless steel, suitable for harsh environment application
- High-precision parts machining to ensure all dimensional quality and precision
- IP68 Ingress protection-grade, that can withstand inner pressure of up to 138kpa or water pressure generated from aircrafts' impact on the optical window
- Interchangeable, modular-designed components, applicable for all series of 12-inch LED in-pavement approach lights(6 mm), which effectively cuts down the inventories.

### Ordering Information

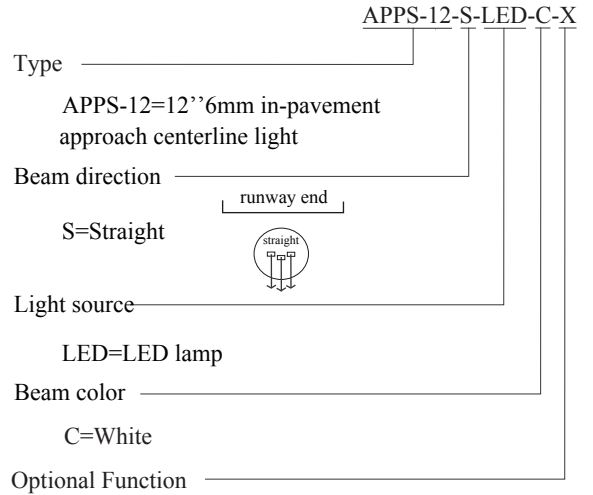

\* Please provide detailed installation info while ordering, spare parts and accessories should be separately ordered with specific order no.

### Installation

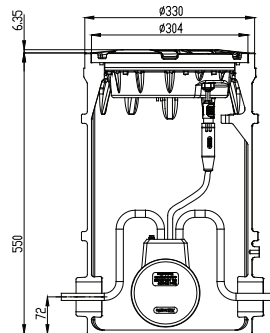

Fig 1 On 12" deep base

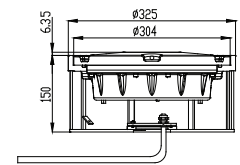
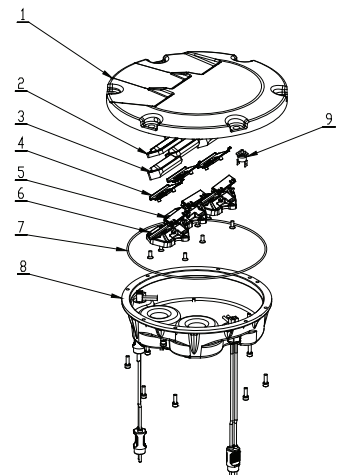

Fig 2. On 12" shallow base

\* Please find detailed information in installation manual

### Structure

1. upper cover
2. prism gasket sleeve
3. prism
4. LED lamp assy
5. prism gasket
6. prism pressing bracket
7. light body gasket
8. inner cover assy
9. thermal switch



## ■ APPS-12-LED

## ■ LED Inpavement Approach Centerline Light(12" 6mm)

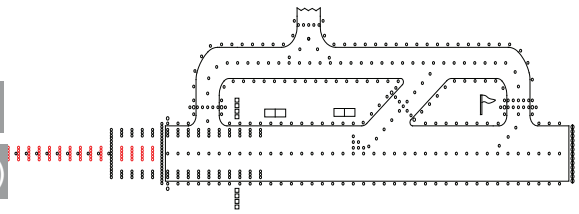

### Specifications

Power: 72VA

Power Factor:  $\geq 0.9$

### Photometric Data

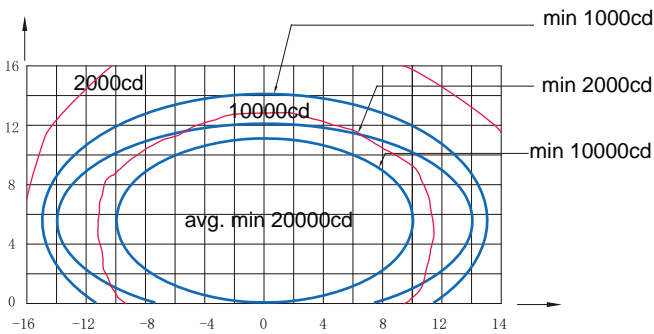

APPS-12-LED (White), ICAO Figure A2-1  
( Vertical main beam coverage 0—11° )

Application		Main beam		Co- lor	Req. min avg. cd	Actual avg. cd
		H	V			
APPS-12 -LED	ICAO Figure A2-1	$\pm 10^\circ$	$0^\circ - 11^\circ$	clear	20000	23561
		$\pm 10^\circ$	$0.5^\circ - 11.5^\circ$	clear	20000	23687
		$\pm 10^\circ$	$1.5^\circ - 12.5^\circ$	clear	20000	23538
		$\pm 10^\circ$	$2.5^\circ - 13.5^\circ$	clear	20000	23569

### Packing Data

1 light w/o base

Unit net weight: 9 kg

1 light w/ 12" shallow base

Unit net weight: 13.42 kg

Packing size: 330×330×150mm<sup>3</sup>

Gross weight: 9.7 kg

Packing size: 350×350×185mm<sup>3</sup>

Gross weight: 14.26 kg

### Spare Parts

struc No.	Part Name	order No.	Description
2	prism gasket sleeve	43117	prism gasket sleeve (61×28)-H6
3	prism	31158	prism (61×28) -H6
4	LED lamp assy	932053 -APPS-C	LED lamp assy-APPS-C
5	prism gasket	43316	prism gasket(67×21)
6	prism pressing bracket	43241	prism pressing bracket(71×65)
7	light body gasket	41135	O-ring 228.27×2.62

### Accessories

No.	Order No.	Description
1	SB-12	12" deep base
2	DB-12	12" shallow base
3	41115	12" base O-ring
4	51121	12" lamp handle
5	ITF-100-066	100-watt isolation transformer
6	REC7	moulded type secondary cable receptacle style 7